

Overpressure Blast Valve

Type A 203

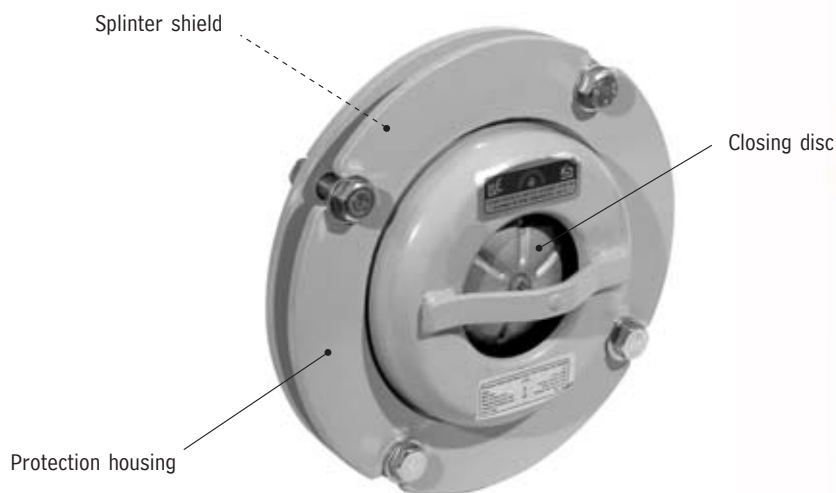

Usage

- Has to be installed inside the shelter, in a vertical position to ensure proper operation
- Has to be installed on an 8" flange according to BS 4504 - PN 6 or DIN 2501 - PN 6
- Should only be installed together with "Noah's Ark" equipment manufactured by Beth-El Industries to ensure maximum performance

Overview

The Overpressure Blast Valve Type **A 203** is a valve used to stop explosive blast waves from entering a bomb shelter as well as to regulate the air pressure in the shelter. The valve is tested and certified to the Israeli Standard 4570 by the Civil Defence Command and the Standards Institution of Israel.

Description

The Overpressure Blast Valve Type **A 203** is designed to release air from the shelter while maintaining a constant overpressure and also to protect against explosive and implosive blast waves. The valve is normally closed. It is maintenance-free and withstands heat and corrosion. The springs are manufactured from special stainless steel and all steel parts are phosphate treated and finished with a powder coating.



Beth-El Zikhron Yaaqov Industries Ltd.
1 Avshalom Road, P.O. Box 166
Zikhron Yaaqov 30951, Israel
Tel.: +972-4-629 9999
Fax: +972-4-629 1110

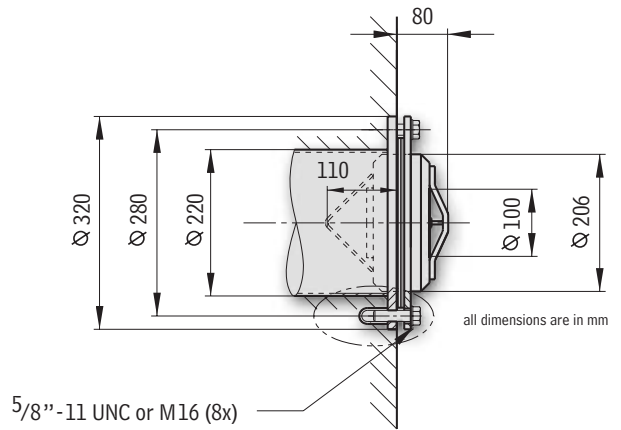
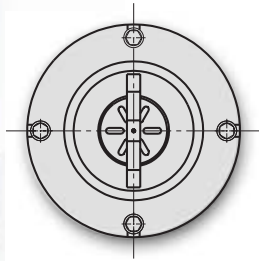
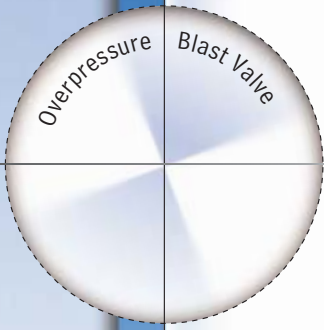

Certifications:

- Tested and certified to IS 4570 by the Standards Institution of Israel
- Approved by the Civil Defence Command of Israel
- Quality Control according to ISO 9001
- Quality Assurance AQAP 120

Pressure Drop on Airflow A 203:

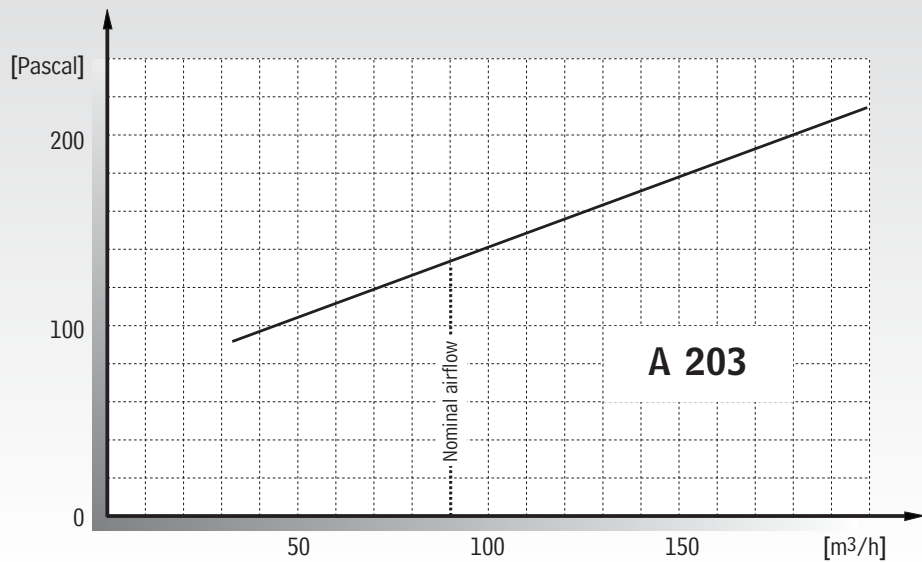

Specifications A 203:

Airflow rate:	50-200 (30-120)	m ³ /h (cfm)
Flow resistance:	see diagram	
Incident pressure durability:	300 (42)	kPa (psi)
Reflected pressure durability:	1100 (154)	kPa (psi)
Working temperature:	+5 to +70 (+40 to +160)	°C (°F)
Mechanical shock resistance:	20	g

Specifications are subject to change without prior notice

