

Overpressure Valve

Type Z 500 D

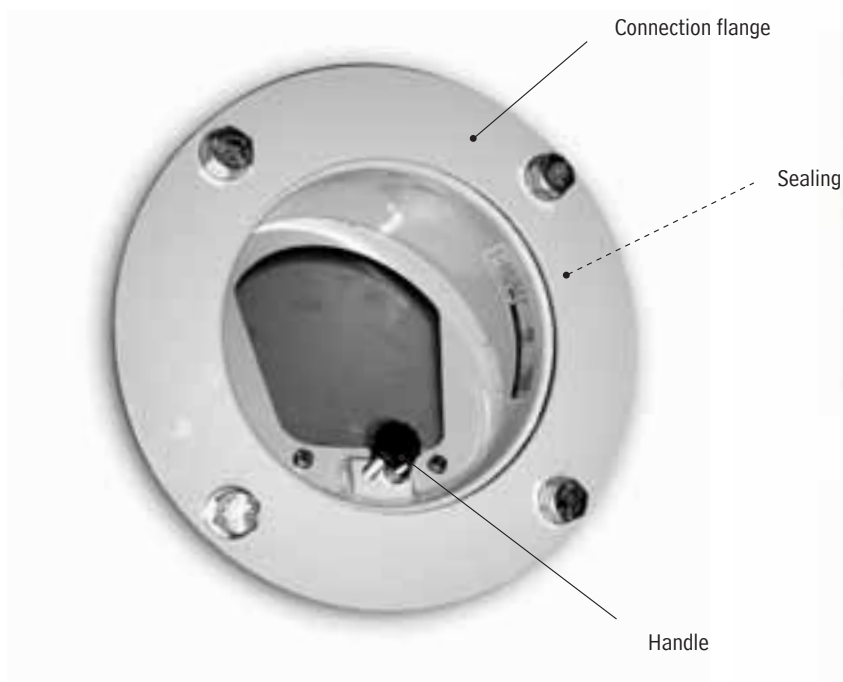

Usage

- Has to be installed between the mainshelter and decontamination area/sanitary rooms.
- Has to be installed on an 8" flange according to BS 4504 - PN 6 or DIN 2501 - PN 6
- Should only be installed together with "Noah's Ark" equipment manufactured by Beth-El Industries to ensure maximum performance

Overview

The Overpressure Valve Type **Z 500 D** is designed to regulate the differential pressure between the different areas inside the shelter. The valve is normally closed. It conforms to the Israeli, Singaporean and Swiss standards. The Valve is tested and certified by the Civil Defence Command and the Standards Institution of Israel.

Description

The Overpressure Valve Type **Z 500 D** is maintenance - free, temperature and corrosion resistant. The differential pressure between rooms may be adjusted to the required value. The valve must be installed only inside the protected area.



Beth-El Zikhron Yaaqov
Industries Ltd.
1 Avshalom Road, P.O. Box 166
Zikhron Yaaqov 30951, Israel
Tel.: +972-4-629 9999
Fax: +972-4-629 1110

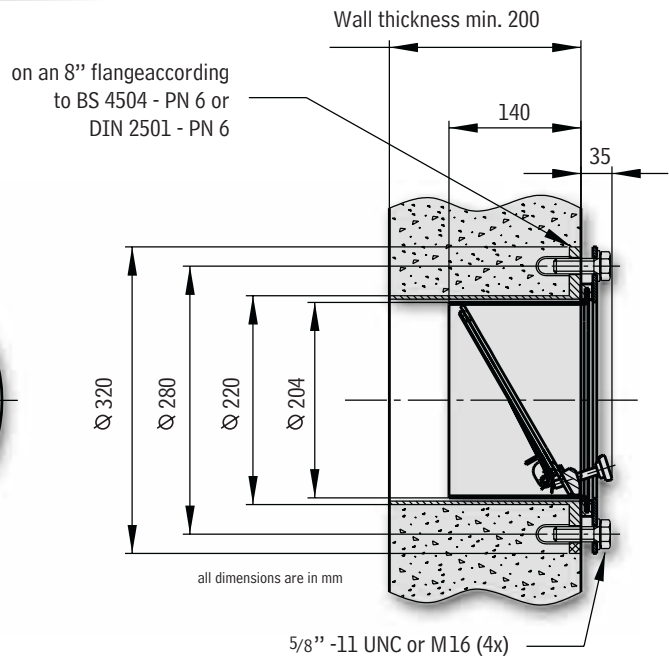
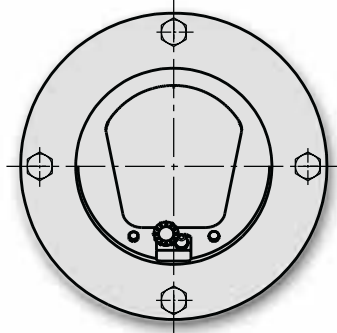
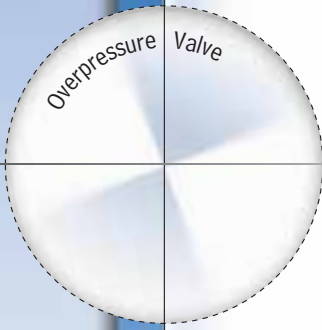

Certifications:

- Tested and certified to IS 4570 by the Standards Institution of Israel
- Approved by the Civil Defence Command of Israel
- Quality Control according to ISO 9001
- Quality Assurance AQAP 120

Pressure Drop on Airflow Z 500 D:

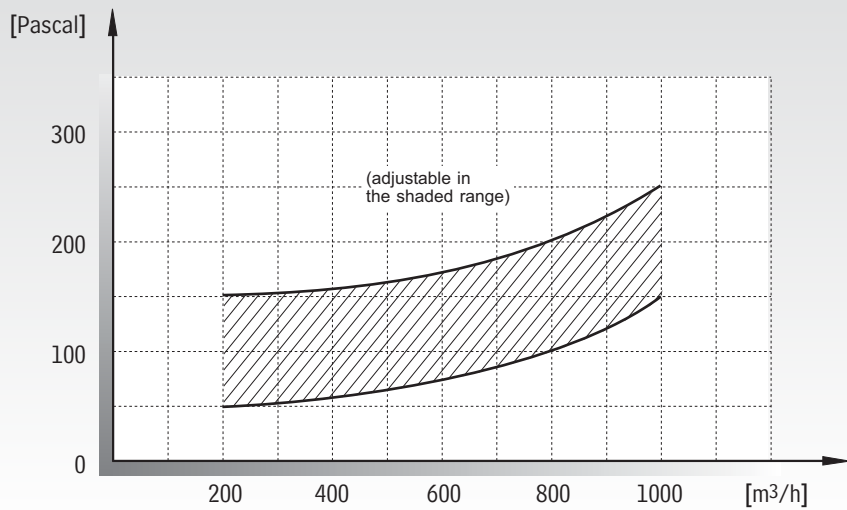

Specifications are subject to change without prior notice

Specifications Z 500 D:

Airflow rate:	0-1000 (0-578)	m ³ /h (cfm)
Flow resistance:	see diagram	
Working temperature:	-5 to +70 (+20 to +160)	°C (°F)
Mechanical shock resistance:	20	g

