

Multi Purpose Blower

Type L 2400/900 (3 phase)

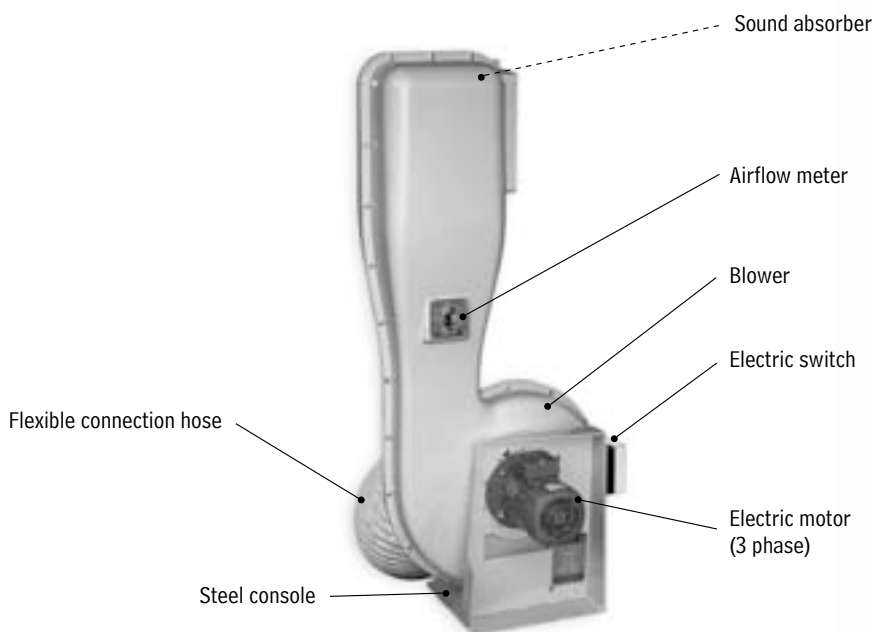

Optional accessories:

- Quick connectors
- Shock absorbers
- Flexible hoses

Usage

- Has to be installed inside the shelter as a part of an NBC-filtration system
- Should only be installed together with "Noah's Ark" equipment manufactured by Beth-El Industries to ensure maximum performance

Overview

The Multi-Purpose Blower Type **L 2400/900** is a high efficient radial blower designed to create pressures up to 2400 Pa (9.4 inchWC). The universal console is intended for attaching to walls and floors. The Blower is tested and certified in accordance with the Israeli Standard 4570 by the Civil Defence Command and the Standards Institution of Israel.

Description

The Multi-Purpose Blower Type **L 2400/900** is designed to draw air through an NBC-filtration system into the shelter in order to create an overpressure in its interior. The radial blower is backward curved and mounted direct on the shaft of the motor. The Multi-Purpose Blower contains an air flow indicator and a Sound absorber. It is maintenance free and corrosion resistant. The housing is manufactured from plastic material, the steel console is phosphate treated and finished with a powder-coating.



Beth-El Zikhron Yaaqov Industries Ltd.
 Avshalom Road 1, P.O. Box 166
 Zikhron Yaaqov 30951, Israel
 Tel.: +972-4-629 9999
 Fax: +972-4-629 1110

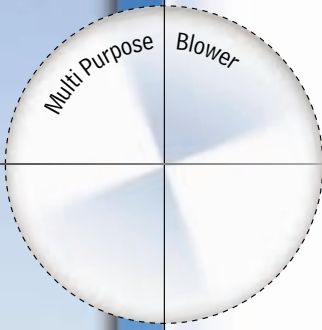

Available as:

- **Wall version**
(Steel console for mounting on the wall)
- **Floor version**
(Steel console for mounting on the floor)

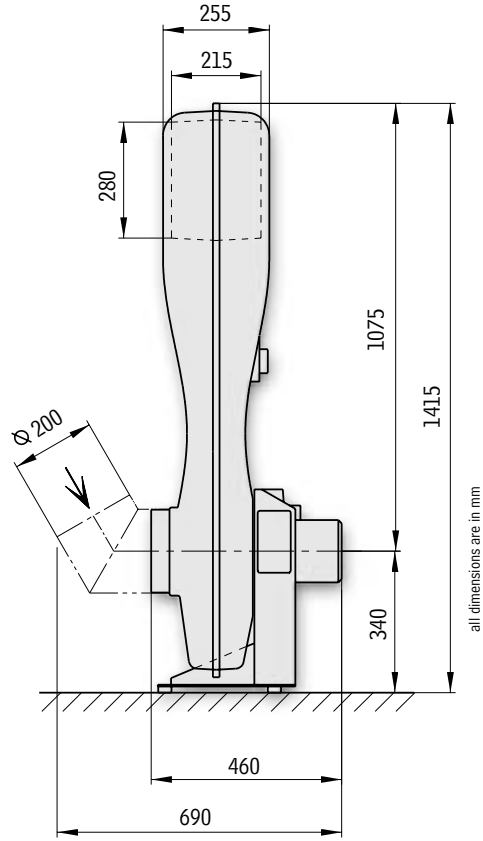
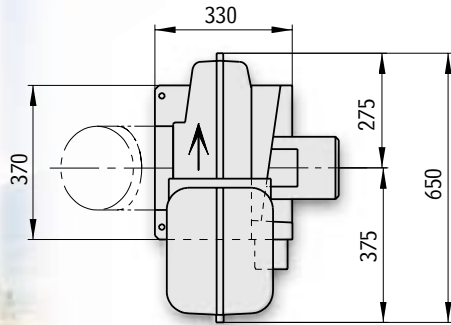

Certifications:

- Tested and certified to IS 4570 by the Standards Institution of Israel
- Approved by the Civil Defence Command of Israel
- Quality Control according to ISO 9001
- Quality Assurance AQAP 120

Static Pressure/Current on Airflow L 2400/900 (3 phase):

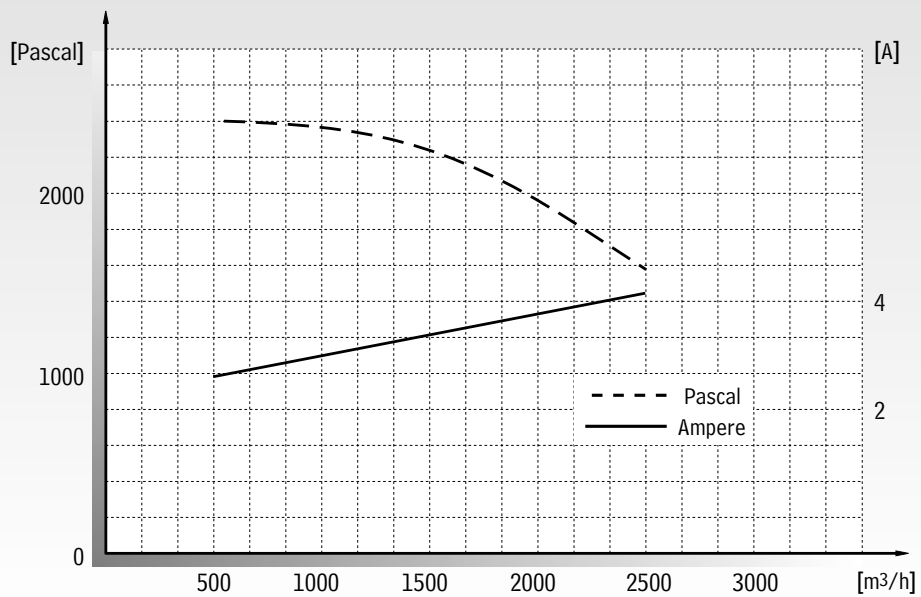

Specifications Electric motor L 2400/900 (3 phase):

Power:	2780	Watt
Voltage 3 phase:	400	Volt
Max. current:	4.1	Ampere
Speed:	2800	rpm
Static pressure:	2400 (9.4)	Pa (inchWC)Noise
level (with sound absorber):	< 70	dB(A)

0117 Specifications are subject to change without prior notice

