

Blast Valve

Type E 803-8"

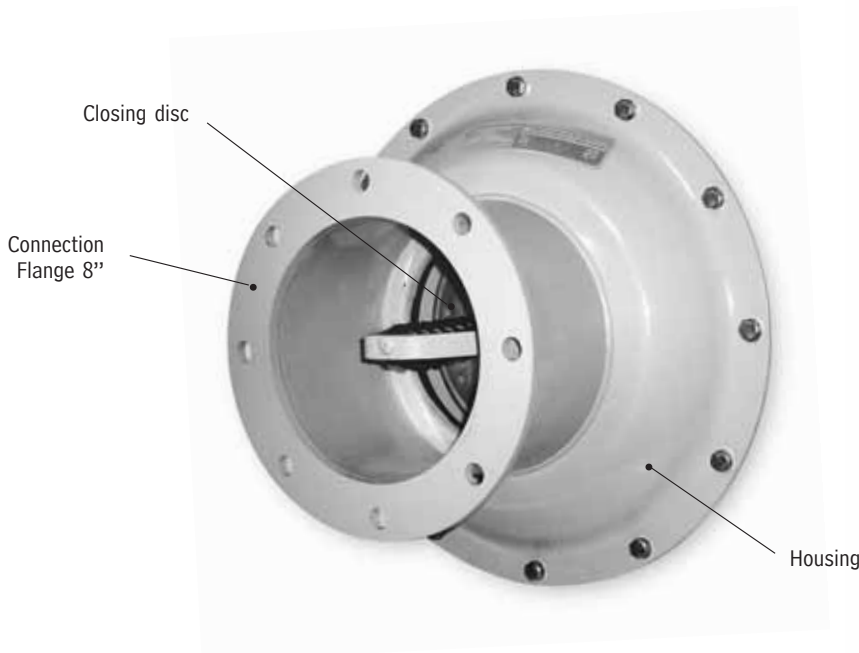

Overview

The Blast Valve Type **E 803-8"** is a heavy duty valve which protects the interior of a shelter from blast waves caused by outside explosions. The valve is normally open. If the air flow rate exceeds the nominal value by approx. 80 %, the valve will close instantly. It can withstand blast waves of 3 bar (42 psi) (infalling pressure). The valve is tested and certified to the Israeli Standards 4570 by the Civil Defence Command and the Standards Institution of Israel.

Description

The Blast Valve Type **E 803-8"** is a valve against explosive and implosive waves. It is maintenance-free, temperature and corrosion resistant. The springs are manufactured from special stainless steel and all steel parts are phosphate treated and finished with a powder coating.

Usage

- Has to be installed at Pipes which enter blast protected shelter
- Should only be installed together with "Noah's Ark" equipment manufactured by Beth-El Industries to ensure maximum performance
- Protects the shelter against blast and vacuum waves after having been correctly installed



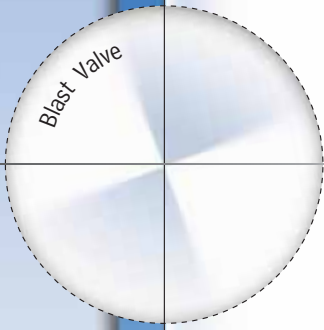

Blast Valve

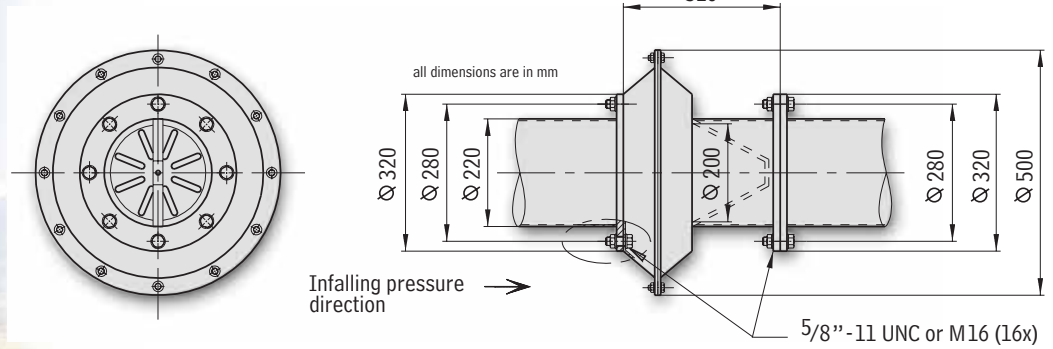

Certifications:

- Tested and certified to IS 4570 by the Standards Institution of Israel
- Approved by the Civil Defence Command of Israel
- Quality Control according to ISO 9001
- Quality Assurance AQAP 120

Pressure Drop on Airflow E 803-8'':

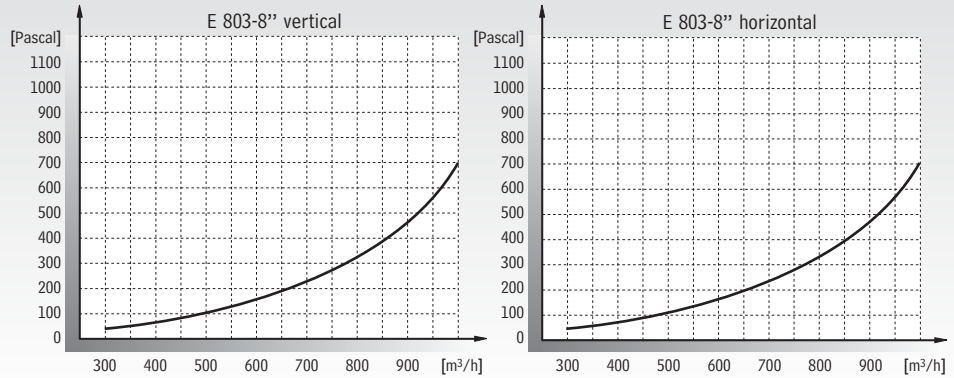

Specifications E 803-8'':

Airflow rate:	150-1000 (89-710)	m³/h (cfm)
Flow resistance:	see diagram	
Incident pressure durability:	300 (42)	kPa (psi)
Reflected pressure durability:	1100 (154)	kPa (psi)
Working temperature:	+5 to +70 (+40 to +160)	°C (°F)
Mechanical shock resistance:	20	g

Specifications are subject to change without prior notice

